

MPA02-CO3.21

Connections and Settings

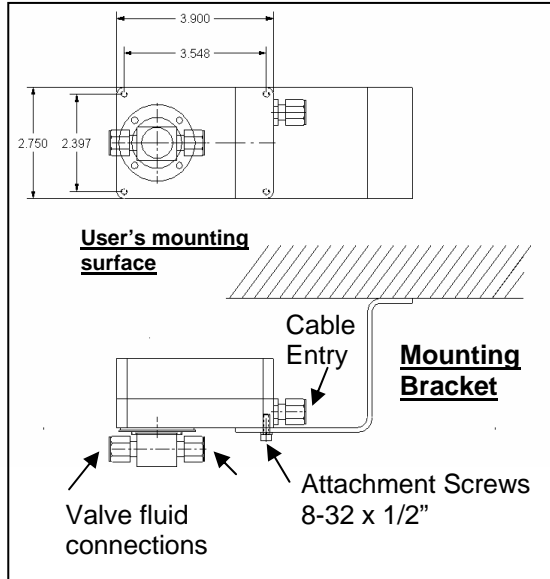

Install Actuator:

Usually, the actuator has to be mounted and supported as shown in the picture to the left. Exceptionally, and only if the application is absolutely vibration free and the tubing is minimum 1/4" dia. stainless, the actuator may be suspended on the tubing itself.

Actuator connection cable:

Select a connection cable with 5 leads if you plan to use an AC power supply and 4 leads if you plan to use a DC power supply.

The liquid tight strain relief on the base of the actuator is designed to accommodate a cable of **O.D. 2.5 - 6.5mm (0.10 - 0.26in)**. Be sure to not use a cable with an OD that is bigger than this!



1.- Remove the liquid tight fitting from the actuator casing and insert the cable into it.



2.- The cable has to be stripped of its jacket for 2 inches (50mm) and the wires need 1/8" (3mm) stripped ends



3.- Bend the wires so that insertion becomes easy



4.- Insert the cable into the actuator base



5.- Put the liquid tight fitting back and tighten (lightly with tool)



6.- Hand tighten the liquid tight fitting to establish seal



7.- Connect wires according to your application (see next page)



8.- Mount actuator cover and tighten 4 screws



OR, if you have ordered the “Turck” cable option:

you can simply cut the cable to the length required and then connect according to the following wire color schematic:



wire color schematic for “Turck” cable:

	DC Power Supply	AC Power Supply
Grey ->	N/C	24VAC
White ->	+24VDC	24VAC
Black ->	Power Gnd	Power Gnd
Brown->	Signal Gnd	Signal Gnd
Blue ->	+ Signal (4..20mA)	+ Signal (4..20mA)

Connect the power:

The **MPA02** may be connected to voltages ranging from: 12 – 24 VDC or 16 - 24 VAC.

The power consumption will range from max. 2.1A to approx 400mA when the actuator is active. When not moving, the actuator draws less than 20mA.

Locate the correct connection terminals as shown in the picture below then connect according to the connection schematics to the right.

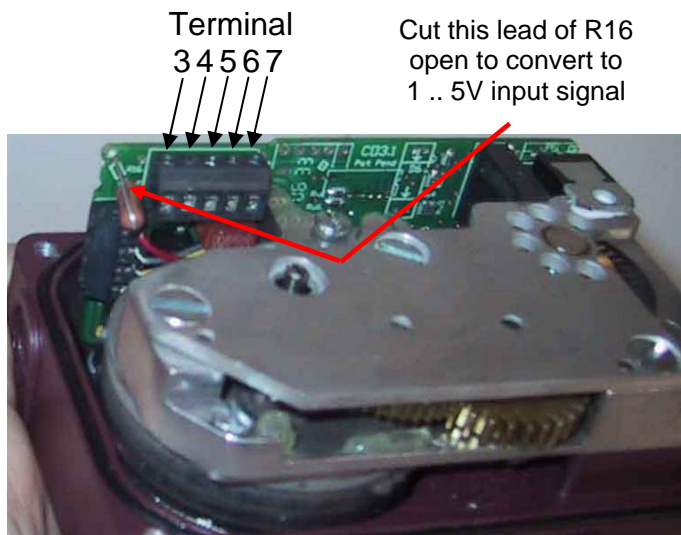
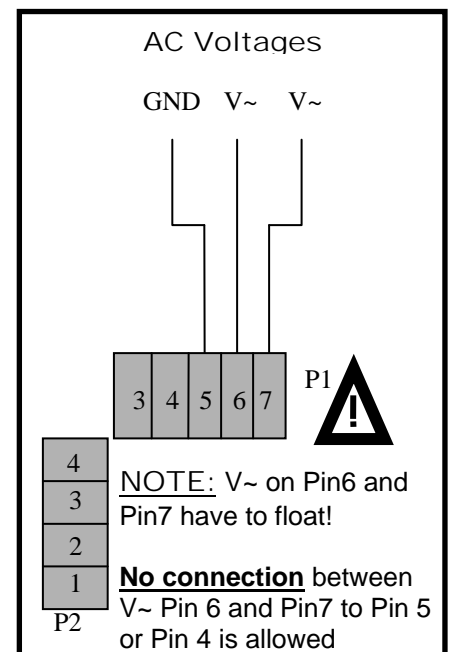
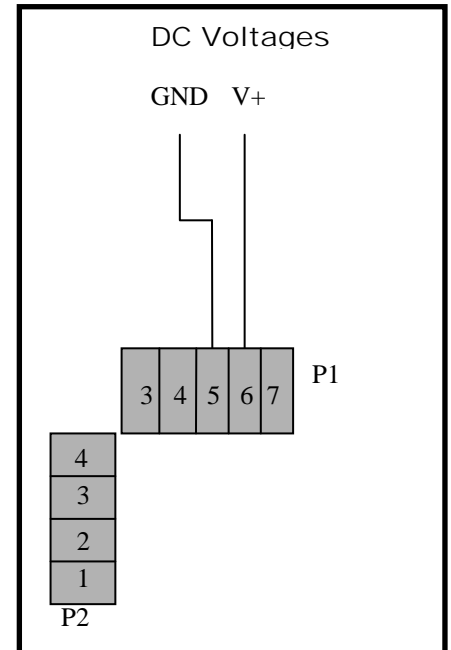

Connect the signal:

Locate the correct connection terminals as shown in the picture above then connect your input signal on pos. 3 and 4 as shown below.

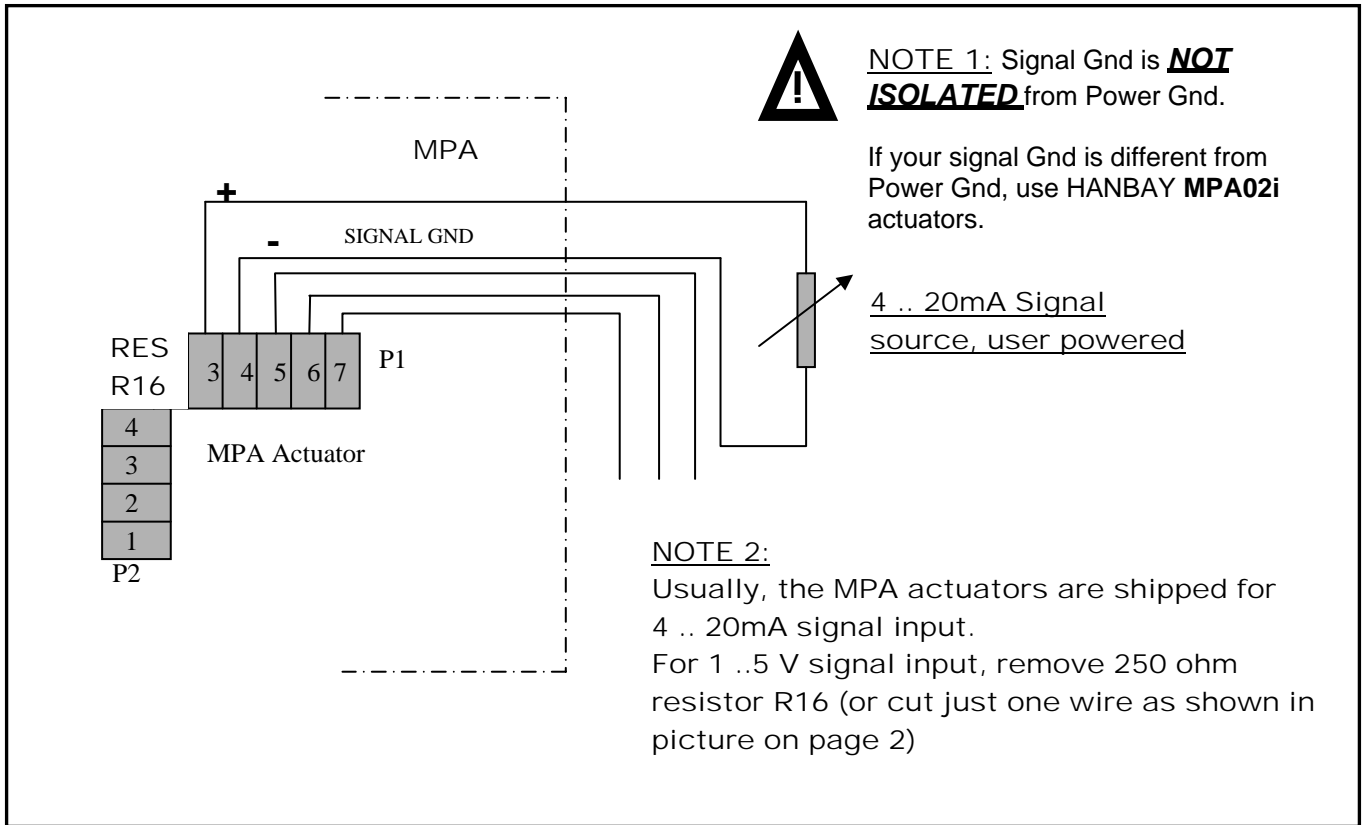

Main Dimensions

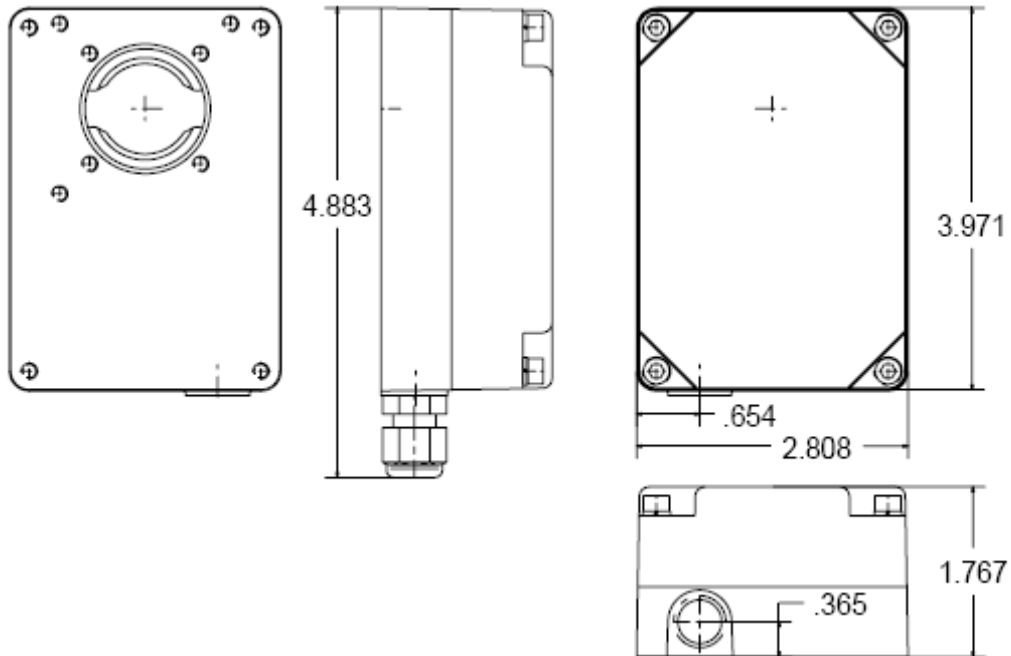

Set the number of turns:

The 4 .. 20mA (or 1.. 5V) input signal represents a total span of a number of turns.

I.e.: If you set the number of turns to 2, then a signal of 12mA will set the actuator to exactly 1 turn from the fully closed position. 15 mA will give: $(15-4)/16=0.6875 \Rightarrow 68.75\%$ of 2 turns $\Rightarrow 1.375$ turns from closed etc.

With the dip switch settings, you can adjust anything between 1 and 15 turns to represent the full signal range of 4 .. 20mA. Check in the table below. (1 = "On" 0 = "Off")

If you require to use the extended range of 16 to 31 turns, please cut the trace on the board as shown below.

Dip4	Dip5	Dip6	Dip7	Trace not cut	Number of turns for full range	Dip4	Dip5	Dip6	Dip7	Trace cut	Number of turns for full range
1	1	1	1	1	reserved	1	1	1	1	0	16
0	1	1	1	1	1	0	1	1	1	0	17
1	0	1	1	1	2	1	0	1	1	0	18
0	0	1	1	1	3	0	0	1	1	0	19
1	1	0	1	1	4	1	1	0	1	0	20
0	1	0	1	1	5	0	1	0	1	0	21
1	0	0	1	1	6	1	0	0	1	0	22
0	0	0	1	1	7	0	0	0	1	0	23
1	1	1	0	1	8	1	1	1	0	0	24
0	1	1	0	1	9	0	1	1	0	0	25
1	0	1	0	1	10	1	0	1	0	0	26
0	0	1	0	1	11	0	0	1	0	0	27
1	1	0	0	1	12	1	1	0	0	0	28
0	1	0	0	1	13	0	1	0	0	0	29
1	0	0	0	1	14	1	0	0	0	0	30
0	0	0	0	1	15	0	0	0	0	0	31

Trace set to "1" cut here to set to "0" for 16 – 31 turns

DIP switch selector

Power and signal connector



Set the speed:

The speed of the actuator can be set by using the first three positions of the **DIP switch selector** that is shown in the picture above. As a result of this setting of the speed, the actuator will work at different speeds and produce different torques as shown in the table below.

The torques available also depend on the voltage provided in the power connection and on the

*Permanent Power settings on DIP 8, 9, 10 as shown below.

Dip1	Dip2	Dip3	Time for 1 turn	Torque in in-lbs		Torque in in-lbs		Torque in in-lbs	
				1/3 Power*		2/3 Power*		3/3 Power*	
				12VDC	24VDC	12VDC	24VDC	12VDC	24VDC
OFF	OFF	OFF	9.0 sec	11	11	18	18	16	24
OFF	OFF	ON	7.6 sec	10	11	16	18	14	22
OFF	ON	OFF	6.2 sec	9	10	14	18	14	22
OFF	ON	ON	4.8 sec	8	10	14	18	11	16
ON	OFF	OFF	3.2 sec	8	10	14	18	11	16
ON	OFF	ON	2.8 sec	8	10	12	18	N/A	N/A
ON	ON	OFF	2.6 sec	8	10	12	14	N/A	N/A
ON	ON	ON	2.5 sec	4	4	N/A	N/A	N/A	N/A

Avoid the N/A area of the settings.

To convert in-lbs to Nm, divide the in-lbs value by 9

To accommodate different valves and other applications, with different torque requirements, the MPA can be set to apply different torque force to the rotary motion on the valve stem. Please see the box to the right and the table above to select the power setting that is right for your application.

The MPA is equipped with an acceleration at the beginning of each move it makes, which results in an increased torque, to “pull” the valve out of its steady state. This increased torque is equivalent to the lowest speed torque for the respective supply voltage, power and speed setting

Permanent power settings:

Dip8	Dip9	Power
On	Off	33%
Off	On	66%
On	On	100%

**100% Zero pullout power setting:
Dip10 -> On**

At first power up, the MPA will completely close the valve to determine its fully closed position. The same function happens every time when the signal goes below 4.01mA.

To deal with sticking valves, at the beginning of the first movement after the seating (“zeroing”) of the valve, the MPA can be set to apply 100%, independently of the setting of the permanent power level. Set Dip10 = On to enable this function.

Note: Pullout setting, 66% setting and 100% setting require voltage supply minimum values as follows:



- Supply voltage needs to be min 20 VDC or 16 VAC for 2/3 setting
- Supply voltage needs to be 24 VDC or 18 VAC for 3/3 setting
- Duty cycle is reduced to 50% - 25% maximum because of the heat that the electronics need to be able to dissipate heat (depending on environmental temperature)



Factory presetting:

We have set your actuator(s) at our factory after mounting the valve and for testing the assembly.

Invoice No.:

Item No.:

Valve Type:

Manufacturer:

Part Number:

Valve

Number of turns:

The Dipswitch settings we applied to your actuator are: (1="On", 0="Off")

Dip1	Dip2	Dip3	Dip4	Dip5	Dip6	Dip7	Dip8	Dip9	Dip10

Notes & recommendations:

