



SERIES H3DM DIRECT MOUNT

Howell 3-Piece DIRECT MOUNT Ball Valve

Easy to Actuate

SPECIFICATIONS:

- Available in Carbon Steel and Stainless Steel
- Full Port Design, 1000 PSI
- Threaded, Socket, Butt Weld, Extended Butt Weld or Flanged Ends
- Blowout Proof Stem for Safety
- ISO 5211 Direct Mounting Pad
- Bottom Entry Stem for Safety
- Anti-Static Device
- Live Loaded Stem Design for High Cycle Life
- Pressure Balanced Ball
- Silicone Free
- Material Traceability
- Size Range: 1/4" to 4"



STANDARDS:

CRN Registered
 Conforms to MSS SP-110
 NACE – MR0175
 EN1024 – DIN 50-049-3.1B
 CE Approved for Europe
 Valve Testing – API 598, MSS SP 61

HOW TO ORDER:

Series	Body	Ends	Seat	Size
H3DM	CS	IP	R - RPTFE *	
	SS	SW	T - PTFE	
		BW	S - 50/50 Stainless/TFE	
		EW	P - Peek	
		FL		

* RPTFE Seats are Standard

Pressure & Temperature Chart

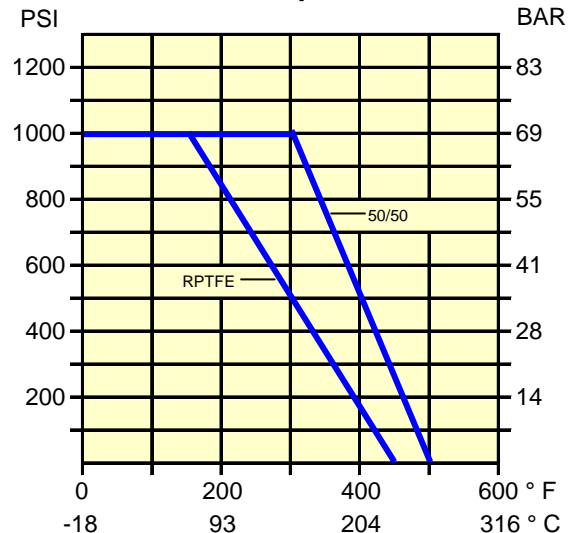

Sample Description and Part# :

H3DM-SS-IP-R-112
 H3DM 3PC SS IP DIRECT MT RPTFE FP BALL 1-1/2"



Head Office:
 Phone: 888 HOWELLS (469-3557)
 Fax: 866-469-3550
 Email: sales@howellvalve.com
www.howellvalve.com

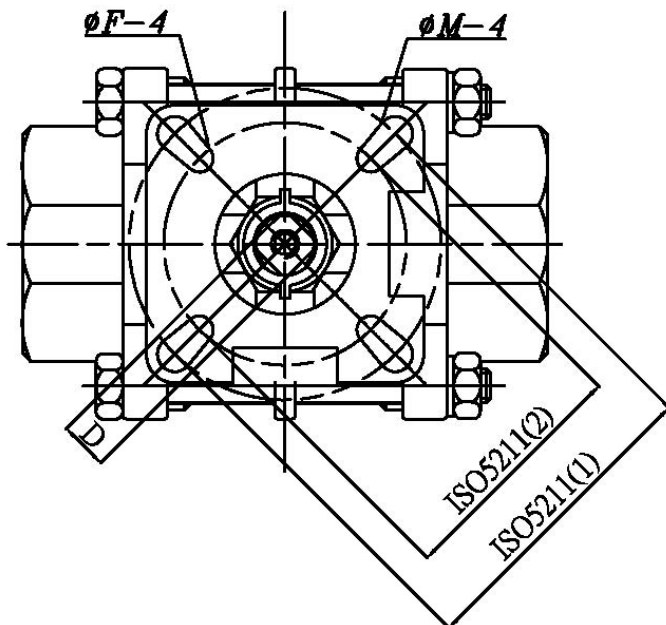
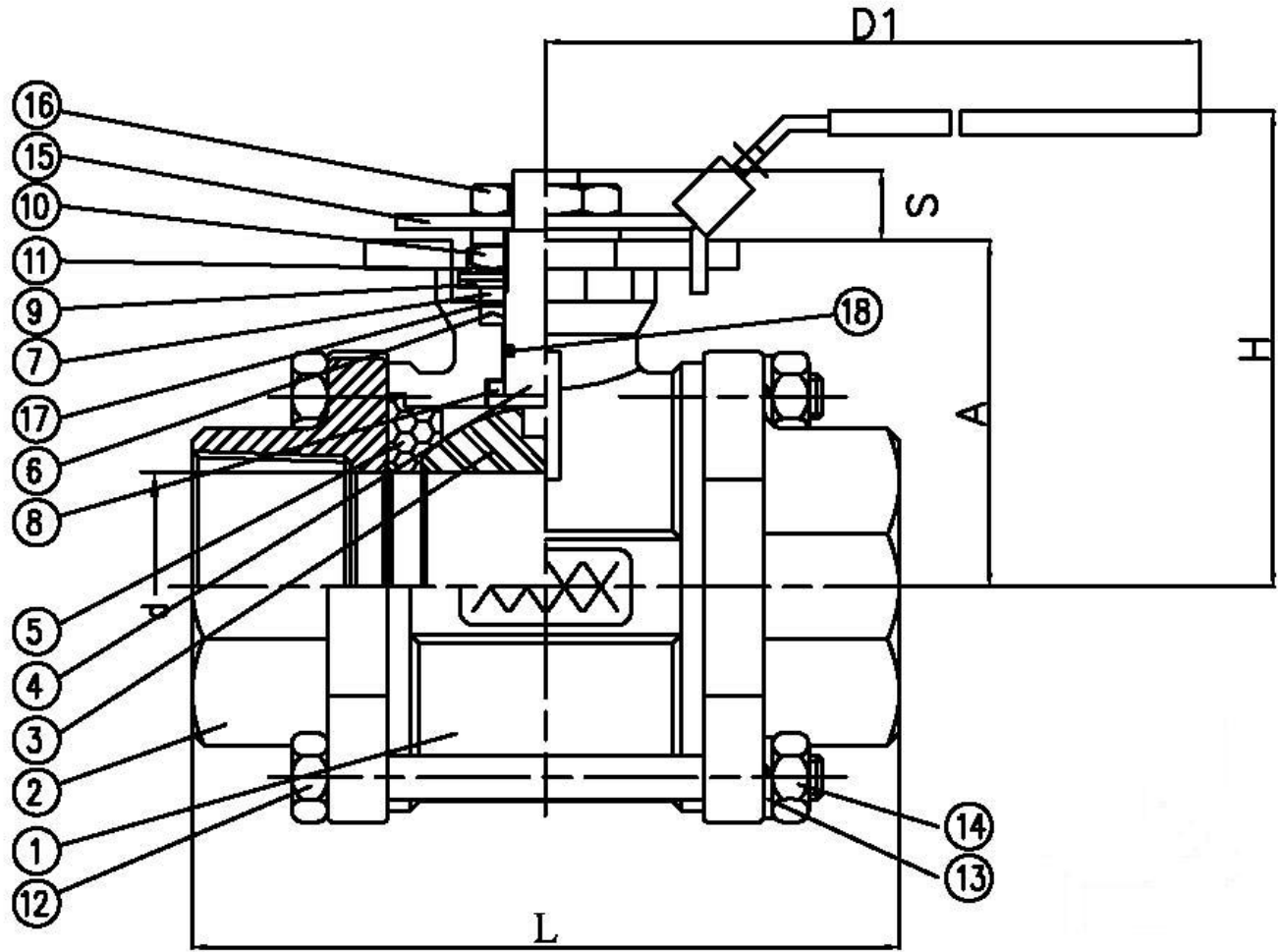

Howell reserves the right to alter design specifications without notice.



SERIES H3DM DIRECT MOUNT

MATERIALS LIST:

Item	Part	For Stainless Steel Valve	For Carbon Steel Valve	Quantity
1	Body	ASTM A351 CF8M	ASTM A216 WCB	1
2	End Cap	ASTM A351 CF8M	ASTM A216 WCB	2
3	Ball	ASTM A351 CF8M	ASTM A351 CF8M	1
4	Stem	316 SS	316 SS	1
* 5	Seat	RPTFE / 15% G.F.	RPTFE / 15% G.F.	2
* 6	Stem Packing	RPTFE / 15% G.F.	RPTFE / 15% G.F.	1
7	Gland Bush	304 SS	304 SS	1
* 8	Thrust Washer	RPTFE / 15% G.F.	RPTFE / 15% G.F.	1
9	Belleville Washer	SUS304-CSP	SUS304-CSP	1
10	Handle Nut	304 SS	304 SS	1
11	Stop	304 SS	304 SS	1
12	Bolts	ASTM 193 B8	ASTM 193 B8	4-6
13	Bolt Washers	304 SS	304 SS	4-6
14	Bolt Nuts	ASTM 194 B8	ASTM 194 B8	4-6
15	Handle	304 SS	304 SS	1
16	Handle Nut	304 SS	304 SS	1
* 17	Thrust Washer	RPTFE / 25% G.F.	RPTFE / 25% G.F.	1
* 18	O-Ring	Viton	Viton	1

* included in repair kit with lock saddle

DIMENSIONS:

SIZE	A		D1		d		D		H		L		S		ISO5211	Ø F-4		Ø M-4	
	IN	MM	IN	MM	IN	MM	IN	MM	IN	MM	IN	MM	IN	MM	(F)	IN	MM	IN	MM
1/4"	1.5	37.0	4.4	112.0	0.5	11.5	0.35	9.0	2.9	73.0	2.5	63.5	0.33	8.5	F03-F04	0.2	6	0.2	6
3/8"	1.5	37.0	4.4	112.0	0.5	12.5	0.35	9.0	2.9	73.0	2.5	63.5	0.33	8.5	F03-F04	0.2	6	0.2	6
1/2"	1.5	37.0	4.4	112.0	0.6	15.0	0.35	9.0	2.9	73.0	2.5	63.5	0.33	8.5	F03-F04	0.2	6	0.2	6
3/4"	1.8	45.0	4.4	112.0	0.8	20.0	0.35	9.0	3.2	80.8	2.9	72.5	0.33	8.5	F03-F04	0.2	6	0.2	6
1"	2.1	53.5	5.4	136.0	1.0	25.0	0.43	11.0	3.6	90.5	3.2	81.0	0.45	11.4	F04-F05	0.2	6	0.3	7
1-1/4"	2.3	59.0	7.3	185.0	1.3	32.0	0.43	11.0	3.9	98.7	3.7	94.5	0.45	11.4	F04-F05	0.2	6	0.3	7
1-1/2"	2.9	74.8	7.8	197.9	1.5	38.0	0.55	14.0	4.5	115.3	4.3	108.0	0.55	14.0	F05-F07	0.3	7	0.4	9
2"	3.3	83.5	7.8	197.9	2.0	50.0	0.55	14.0	4.9	124.0	4.8	121.5	0.54	13.7	F05-F07	0.3	7	0.4	9
2-1/2"	4.3	108.8	10.4	264.0	2.6	65.0	0.67	17.0	6.1	155.0	6.2	157.5	0.71	18.0	F07-F10	0.4	9	0.4	11
3"	4.7	118.3	10.4	264.0	3.1	80.0	0.67	17.0	8.2	208.5	7.5	190.0	0.71	18.0	F07-F10	0.4	9	0.4	11
4"	6.1	153.8	12.8	325.0	3.9	100.0	0.87	22.0	8.5	216.7	8.9	225.0	0.91	23.0	F10-F12	0.4	11	0.5	13

Break Away Torques

Size	(in/lbs)
1/4"	35
3/8"	35
1/2"	44
3/4"	71
1"	106
1-1/4"	133
1-1/2"	186
2"	354
2-1/2"	451
3"	611
4"	752

Estimated Cv Values

Size	Cv Value
1/4"	18
3/8"	18
1/2"	18
3/4"	42
1"	74
1-1/4"	130
1-1/2"	210
2"	380
2-1/2"	645
3"	890
4"	1620

Valve Weights

Size	(KG)	(LB)
1/4"	0.5	1.0
3/8"	0.5	1.0
1/2"	0.6	1.3
3/4"	0.8	1.8
1"	1.1	2.5
1-1/4"	1.7	3.8
1-1/2"	2.5	5.5
2"	3.4	7.4
2-1/2"	6.8	15.0
3"	11.3	25.0
4"	19.0	42.0