

MODEL 808Y

CRYOGENIC NEEDLE VALVE

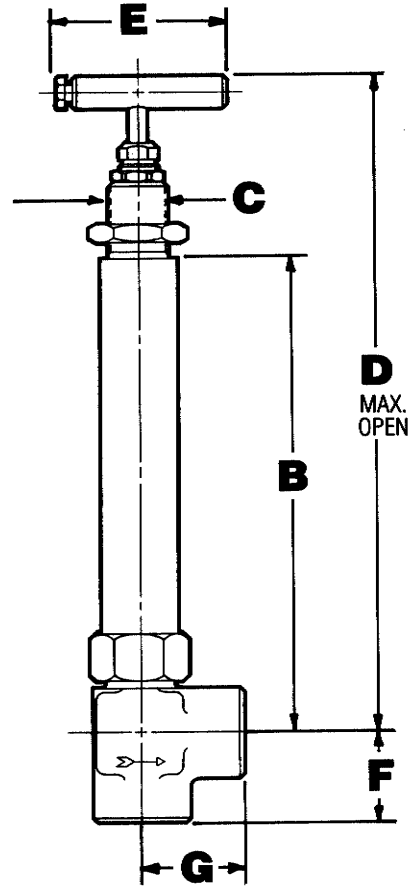
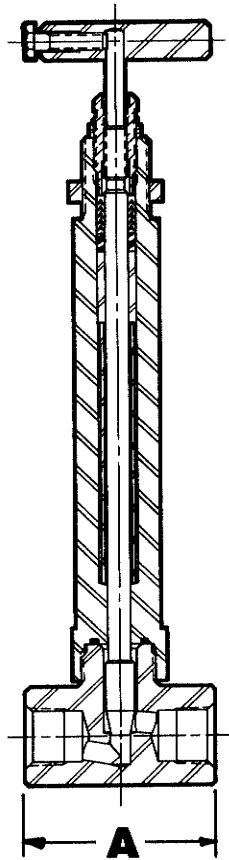

SPECIFICATIONS

OPERATING PRESSURE: ¼-½ 10,000 PSI AT -370° F
 ¾-1 6,000 PSI AT -370° F
 TEMPERATURE RANGE: -370° F TO +450° F
 FLOWING MEDIUM: LIQUID OXYGEN OR LIQUID NITROGEN
 CLEANING: CLEANED AND PACKED FOR LOX PER APPLICABLE
 SPECS, AS SPECIFIED; ADDITIONAL CHARGE

BILL OF MATERIALS

QTY. ASSY	PART NAME	MATERIAL
1	BODY	STAINLESS STEEL TY 316
1	STEM	17-4 PH
1	GASKET	TEFLON
1	STOP NUT	STAINLESS STEEL TY 316
1	SPACER	STAINLESS STEEL TY 304
1	SLEEVE	STAINLESS STEEL TY 316
1	PACK SET	TEFLON* (Avail. KEL F)
1	PACK RING	TEFLON* (Avail. KEL F)
2	LOCK NUT	ST. STL. 300 SERIES
1	PACKING FOLLOWER	BRONZE AMPCO GR45
1	CAP SCREW	ST. STL. 300 SERIES
1	HANDLE	ST. STL. 300 SERIES

DIMENSIONS

¼	2	7	¾	9¾	2 ⁷ / ₁₆	1 ⁵ / ₁₆	1 ¹ / ₁₆	¾	2 ½ lb.
½	2 ½	7 ³ / ₁₆	7 ⁷ / ₈	11	3 ³ / ₁₆	1 ¼	1 ¼	1 ⁷ / ₆₄	3 ½ lb.
¾	3	7 ⁷ / ₈	1 ½	11 ¼	3 ³ / ₁₆	1 ½	1 ⁵ / ₈	1 ¹ / ₃₂	6 ½ lb.
1	4 ¼	8	1 ¾	13 ³ / ₈	4 ³ / ₄	2 ¹ / ₈	2 ¹ / ₈	1 ⁵ / ₃₂	9 lb. 14 oz.
SIZE	A	B	C	D	E	F	G	ORIF.	WGT. LBS.

ORDERING INSTRUCTIONS

PART NO. EXAMPLE: 808Y 0 5 4

BODY TYPE	MATERIAL	CONNECTIONS		PKG. OPTION
0	5	AISI 316	3 ¼ NPT	8 ½ TUBE AN8
			4 ¼ TUBE AN 4	11 ¾ NPT
7	5	AISI 316	7 ½ NPT	15 1 NPT
				16 1 TUBE AN16

When Ordering KEL F Pack Set and Pack Ring, Add Suffix K to Part No.