

LCx-xxxAx-8.06 Linear

Contents

| | |
|-----------------------------|-------|
| Installation | pg1-3 |
| Mounting | pg1 |
| Wiring | pg2 |
| Connecting Power and Signal | pg2-3 |
| Operation | pg4-6 |
| DIP Switch settings | pg4 |
| Controlling the Actuator | pg4 |
| Torque Settings | pg5 |
| Signal loss and Calibration | pg5-6 |
| Troubleshooting | pg6 |
| Appendix | pg6-8 |
| Changing number of turns | pg6-7 |
| Speed and Power Details | pg7 |
| Dimensions | pg8 |
| Installing a cable | pg8 |
| Factory Presets | pg10 |



Installation

Mounting:

Usually, the actuator has to be mounted and supported as shown in the picture to the left. Exceptionally, and only if the application is vibration free and the tubing is minimum 1/4" dia. stainless, the actuator may be suspended on the tubing itself.

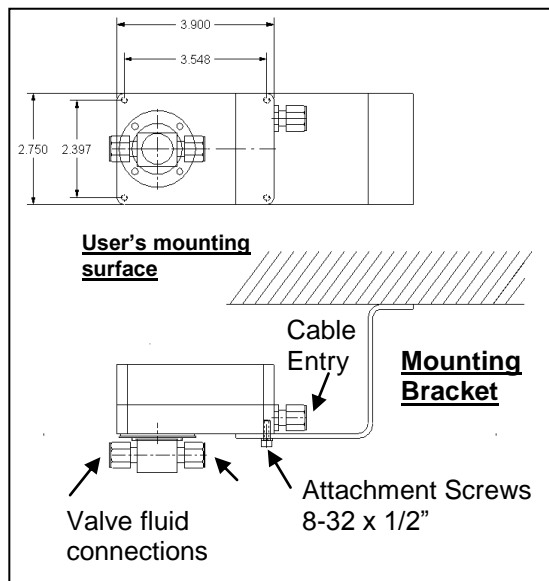

Wiring:

The actuator comes standard with a Turck 5 position connector and a 20' cable with plug. Cut the cable to the length required and then connect according to the following wire color schematic:



Wire color schematic for “Turck6” cable:

| Pin | Colour | Function |
|-----|----------|-------------------------------------|
| 6 | White -> | +24VDC |
| 5 | Black -> | Power Gnd |
| 4 | Grey -> | Output Signal (4..20mA)* |
| 3 | | Not connected |
| 2 | Brown-> | Isolated** Input Signal Gnd |
| 1 | Blue -> | Isolated** Input + Signal (4..20mA) |

* “feedback” available in LCx-xxxAF version of actuator only

** “isolated” available in LCx-xxxAI and xxxAF versions of actuator only

Otherwise, if the Turck cable is not included in your actuator, see pg.8 for more detailed wiring instructions.

Connect the power:

The LCx may be connected to voltages ranging from: 12 – 24 VDC. 18 VDC is required for full ‘Digital Potentiometer’ functionality (see pg. 7)

The power consumption will range from max. 3.0A to approx min. 100mA when the actuator is active. When not moving, the actuator draws less than 10mA. The LCx-xxxAF feedback model will draw up to 60mA more.

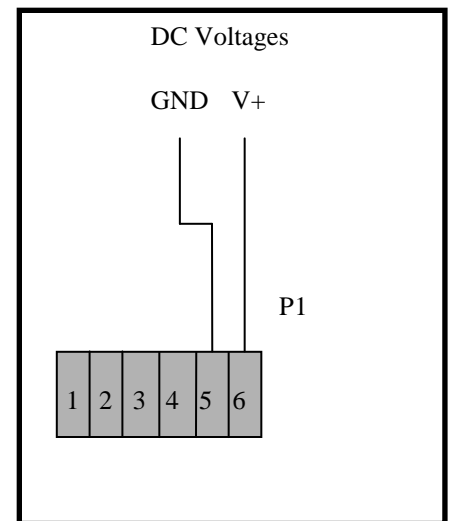

Remove R16 to convert to 1 .. 5V input signal

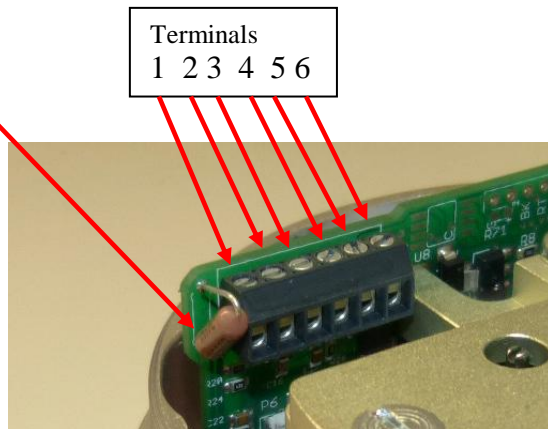

Locate the correct connection terminals as shown in the picture to the left then connect according to the connection schematics above.



Connect the signal:

Locate the correct connection terminals as shown on the previous page, then connect your input signal on pos. 1 and 2 as shown below. Feedback, if applicable, is connected to pos. 3.

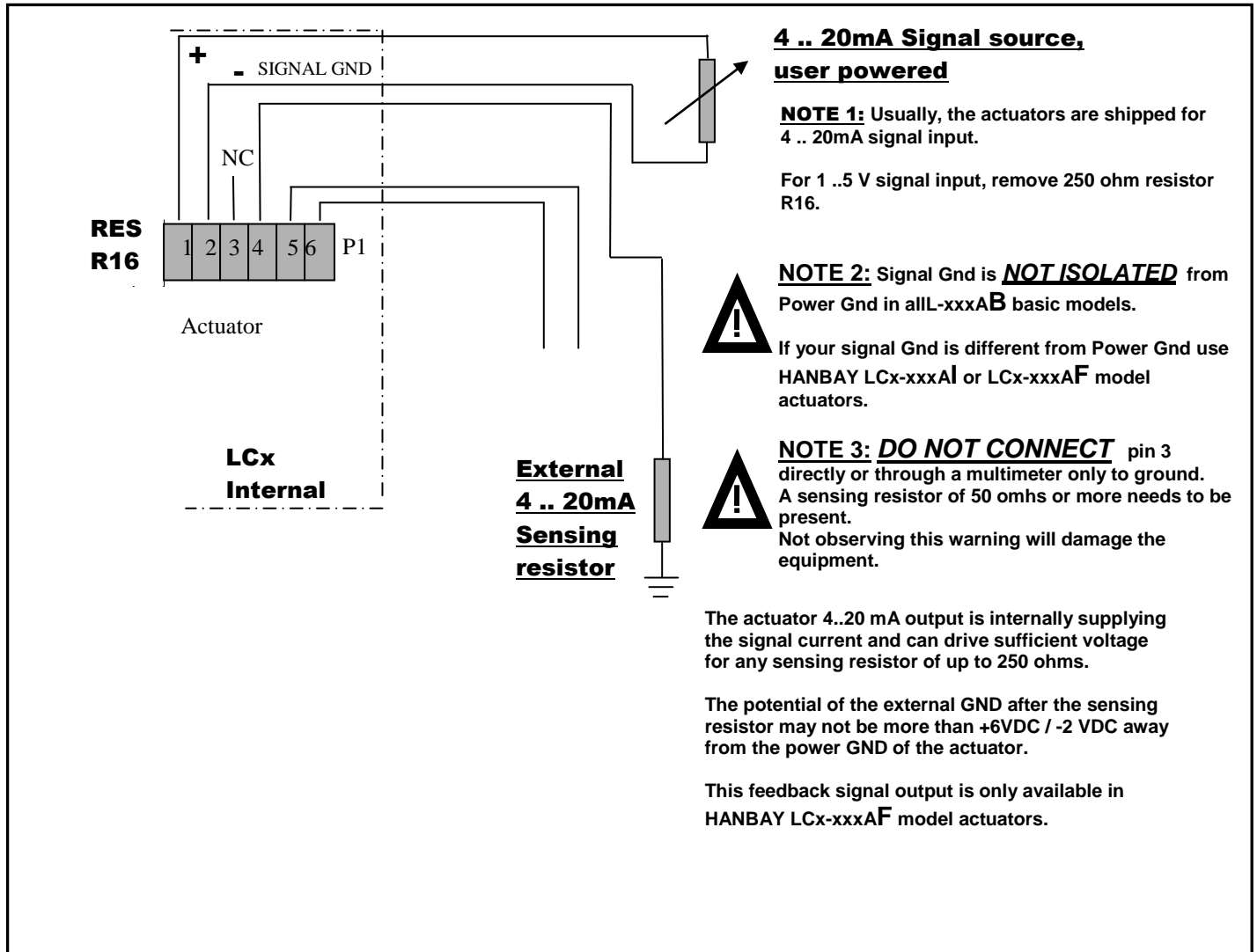

Operation

DIP switches:

The DIP switches allow you to change the settings on your actuator. To flip a switch, gently use a small flat-head screwdriver. See chart on next page for DIP switch functionality.

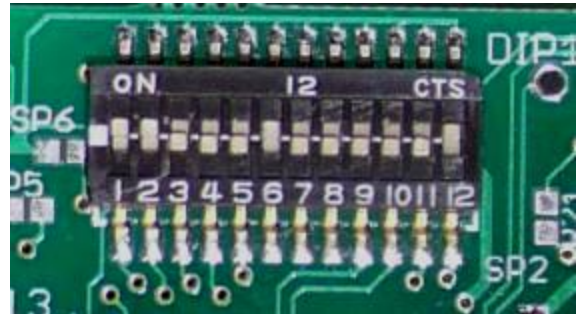

In this example DIPs 1, 2, 6 and 12 are on.

| DIP | Function |
|-----|---|
| 1 | Speed: Choose how quickly the actuator will turn the drive wheel. See pg 6-7. |
| 2 | |
| 3 | Stroke: The actuator usually ships from the factory with the recommended stroke for the valve. This number can be changed however. See pg 6-7 for relation between position of the dip switches vs. stroke. Turning on a switch will add that amount of stroke to the actuator's movement. |
| 4 | |
| 5 | |
| 6 | |
| 7 | |
| 8 | |
| 9 | Signal loss: See below. |
| 10 | Power: Set how much torque the actuator exerts on the valve lever. See below and pg 6-7. |
| 11 | |
| 12 | Direction/Calibration: Toggle switch on and off while powered to re-calibrate actuator. Also sets direction in which the actuator will open and close. See pg 5. Example: The MCM model actuator turns clockwise when the signal is decreased with DIP 12 in the OFF position. For changes to rotation to take affect flip the switch and cycle the power to the actuator. |

Controlling the Actuator:

The 4 .. 20mA (or 1.. 5V) input signal is proportional to the stroke of the valve.

Example: You have an actuator with TPI=16 (standard). Valve stroke is 0.75". You wish to move the actuator so the valve's position is 0.122" above the closed position. $0.122/0.750=0.163$ 20mA-4mA= range of 16mA. $0.163*16=2.608$. $2.608+4mA=6.608mA$. To get 0.122" above the closed position, supply signal of 6.608mA to the actuator.



Torque Settings:

To accommodate different valves and other applications with different torque requirements, the actuator can be set to apply different torque on the valve stem.

Please see the box to the right and the tables on pg 6-7 to select the power setting that is right for your application.

The actuator will try to reach the speed set by Dip1 and Dip2. If the torque required is too high, the actuator will automatically slow down and deliver the maximum available torque for a given "Permanent Power Setting".

Permanent power settings: (when operating at 24V)

| Dip10 | Dip11 | Power |
|-------|-------|-------|
| Off | Off | 16% |
| Off | On | 33% |
| On | Off | 66% |
| On | On | 100% |

To deal with sticking valves, at the beginning of the first reversing movement after the seating ("zeroing") of the valve, the actuator will apply double the power set by Dip10 and Dip11 (up to 100% power.) This "pull out" function is always enabled.



Warning: High power settings can supply enough torque to damage your valve. Please be cautious, especially when using the 100% power setting.

Signal Loss and Calibration:

1. - **For actuators that are not connected to a UPS** (Uninterruptible Power Supply), the loss of signal will be simultaneous with power loss. As a consequence, the actuator will not be able to move anywhere. In the shutdown process though, the actual position is automatically saved to the internal EEPROM. [this saving of the position is only happening for min. 18VDC supplies]

When power is restored, the actuator will "know" its location and will simply start to follow the signal as received.



IF YOU HAVE TO turn the actuator manually when its power is turned off, it will lose its position, and it will need to be re – zeroed (as described in section 3 on the following page).

2. - **For actuators that are connected to a UPS** the behavior on signal loss can be set as follows:

Normal position of DIP9: OFF

With DIP9 in the off position, the actuator will ignore the signal if it is lost (I.E.: if the signal falls below 0.7V) and simply remain in its current position.

Note: if the sensing resistor R16 is removed (for 1..5V input signals), we recommend placing a 10K resistor between signal and signal GND.

Predetermined signal loss position DIP9: ON

With DIP9 in the on position, the actuator will move to a predetermined position when the signal is lost (I.E.: if the signal falls below 0.7V).

Setting of the predetermined signal loss position:

- a. - turn Dip9 to the "off" position
- b.- re – zero the actuator by sending and holding an input signal between 2.8 and 4.16 mA (0.7 to 1.04V) wait until the device is re-zeroed, (i.e: the valve is closed)
- c. - by varying the input signal, move the actuator to the position that is going to be the predetermined signal loss position.



- d. - switch Dip9 to the “on” position. The current actuator position will be saved as the default signal loss position. (The default signal position is an absolute actuator position. I.e.: not a signal value.)
3. - **Re – Zeroing the actuator and initiating calibration routine:**
 The actuator will re-zero when the input signal is between 2.8 and 4.16mA (0.700V – 1.040V). It will turn clockwise until the actuator has reached the fully closed position of the valve.
Different valves mounted to actuator need the calibration routine initiated manually. This is done by toggling dip switch 12 in the one way and back to its original position while the actuator is powered. This will initiate the calibration routine and is essential when changes have been made to the valve.
If you need to re-zero in the opposite direction (i.e: for pressure regulators, which typically go to the “top” fully open position at 4mA) change the setting of Dip switch DIP12 and cycle power.
4. - **Feedback calibration: [LCx-xxxAF model actuators only]**
 The current feedback will be calibrated from the factory.
 To re-calibrate the feedback:
- a.- turn off the actuator, and disconnect the feedback and input signals
 - b.- connect the feedback signal to the signal input. Also connect the power and signal grounds.
 - c.- power up the actuator with this “signal back-loop” setup.
 - d.- Short SP5. It will automatically run a special routine to calibrate the feedback signal to the signal input.
 The whole process takes about 1.5 seconds.
 - e.- turn off the power and reconnect the actuator as normal.

Troubleshooting:

Upon noticing a problem, your first step should almost always be to recalibrate the actuator by switching DIP 12, then switching it back to its original position, all while the actuator is powered. This alone can solve basic problems. See section 3 on this page for more details.

If the actuator does not move, try following these steps:

- 1) Re-calibrate the actuator. This will move the actuator regardless of what signal it is receiving.
- 2) A sticking valve may be the problem. Remove the valve from the actuator, and re-test the actuator.
- 3) Remove power. Re-check the wiring and the power/signal apparatus. Power actuator, and re-calibrate. If the problem persists, please call Hanbay for technical support.

Appendix

Changing the stroke length:

Set the stroke according to the table below. Standard actuator has 16 Threads Per Inch, TPI=16.

Example: You have an actuator with TPI = 8, and you have a valve with a stroke of 0.605”. The stroke of the actuator should not exceed the stroke of the valve. With TPI=8 we have 0.125” increments, so the next lowest is 0.500”. Actuator must be set to 0.500” stroke maximum. Consult table on page 7. Since TPI=8, values on table must be doubled. Therefore you select the setting for quarter inch and adjust the DIP switches accordingly.



| Total Stroke Dip4=0 | Dip5 | Dip6 | Dip7 | Dip8 |
|------------------------|------|------|------|------|
| reserved | 0 | 0 | 0 | 0 |
| 0.0625" | 0 | 0 | 0 | 1 |
| 0.125" | 0 | 0 | 1 | 0 |
| 0.1875" | 0 | 0 | 1 | 1 |
| 0.25" | 0 | 1 | 0 | 0 |
| 0.3125" | 0 | 1 | 0 | 1 |
| 0.375" | 0 | 1 | 1 | 0 |
| 0.4375" | 0 | 1 | 1 | 1 |
| 0.5" | 1 | 0 | 0 | 0 |
| 0.5625" | 1 | 0 | 0 | 1 |
| 0.625" | 1 | 0 | 1 | 0 |
| 0.6875" | 1 | 0 | 1 | 1 |
| 0.75" | 1 | 1 | 0 | 0 |
| 0.8125" | 1 | 1 | 0 | 1 |
| 0.875" | 1 | 1 | 1 | 0 |
| 0.9375" | 1 | 1 | 1 | 1 |

These settings are for TPI=16, which is standard.

For actuators with TPI=8, the stroke length is doubled.

Turn on DIP4 for 1.00" stroke. **This is the maximum stroke of this actuator, do not exceed.**

WARNING: Stroke can be set for a maximum of 1.00", otherwise unit will stall. Also be sure that the stroke of the actuator for LESS than the stroke of the the valve. The actuator should not stop itself on a fully opened valve. It can damage the valve, and the actuator will lose its position.

Speed and Power Details:

The maximum speed of the actuator can be set by using the first two positions of the DIP switch selector. As a result of this setting, the actuator will limit the maximum speed. The tables below show the maximum torques that can be expected at the given maximum speeds.

The torque available also depends on the voltage provided in the power connection and on the Permanent power settings on DIP 10, 11 as shown below. *

Power: For LCJ, divide LCL values by 3. For LCK, divide LCM values by 3

| | | Power setting / Force in lbs | | | |
|-------|-----|------------------------------|---------|--------|--------|
| Gears | TPI | 100% | 66% | 33% | 16% |
| LCL | 8 | 517 | 341.22 | 170.61 | 82.72 |
| LCM | 8 | 1551 | 1023.66 | 511.83 | 248.16 |
| LCL | 16 | 739 | 487.74 | 243.87 | 118.24 |
| LCM | 16 | 2217 | 1463.22 | 731.61 | 354.72 |

Speed:

| | Seconds per inch | | | |
|---------|------------------|-----|-----|-----|
| DIP 1 | on | on | off | off |
| DIP 2 | on | off | on | off |
| LCL -8 | 8 | 24 | 32 | 40 |
| LCM -8 | 32 | 64 | 96 | 128 |
| LCL -16 | 16 | 48 | 64 | 80 |
| LCM -16 | 64 | 128 | 192 | 256 |



Main Dimensions:

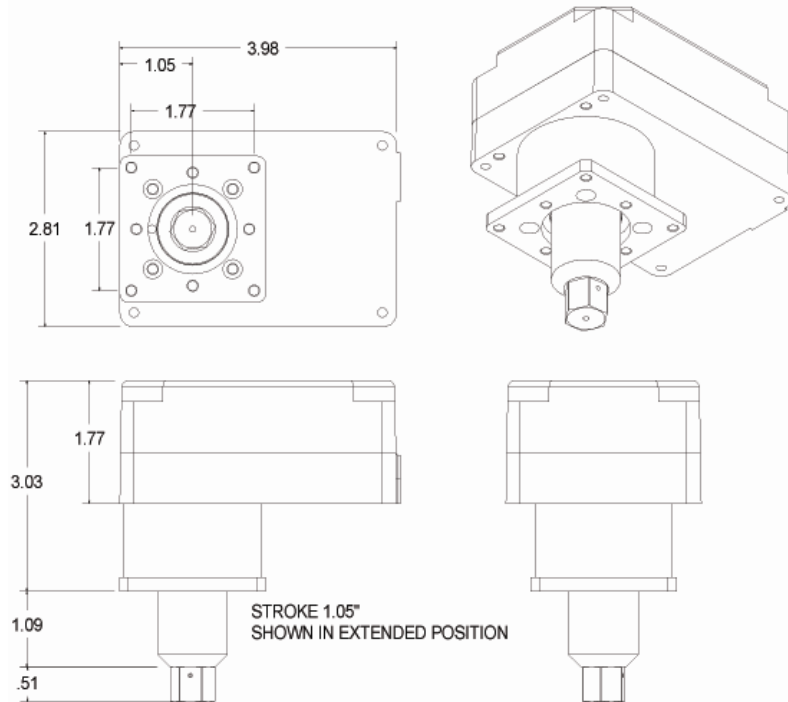

Cable Installation:

Select a connection cable with 5 leads.

The liquid tight strain relief on the base of the actuator is designed to accommodate a cable of O.D. 2.5 - 6.5mm (0.10 - 0.26in). Be sure to not use a cable with an OD that is no bigger than this!



1.- Remove the liquid tight fitting from the actuator casing and insert the cable into it.



2.- The cable has to be stripped of its jacket for 2 inches (50mm) and the wires need 1/8" (3mm) stripped ends.



3.- Bend the wires so that insertion becomes easy.



4.- Carefully insert the cable into the actuator base. Mind the red motor cable and its plug into the board. Moving the plug out of its fully inserted position may cause malfunction of the actuator.



5.- Put the liquid tight fitting back and tighten (lightly with tool).

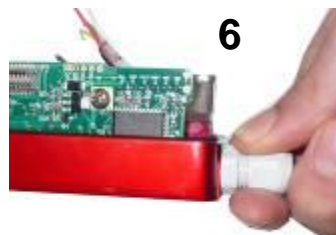

6.- Hand tighten the liquid tight fitting to establish seal.



7.- Connect wires according to your application (see page 2,3).



8.- Mount actuator cover and tighten 4 screws.



Factory Presetting

Invoice No:
Line item :

Full Hanbay Part Number:

| | | | | | | | | | | | | | | |
|---|---|--|--|--|--|--|--|---|--|--|--|--|--|--|
| L | C | | | | | | | A | | | | | | |
|---|---|--|--|--|--|--|--|---|--|--|--|--|--|--|

 -

| | | | | | | | |
|--|--|--|--|--|--|--|--|
| | | | | | | | |
|--|--|--|--|--|--|--|--|

 -

| | | |
|--|--|--|
| | | |
|--|--|--|

 -

| | | | | | | | | | | | |
|--|--|--|--|--|--|--|--|--|--|--|--|
| | | | | | | | | | | | |
|--|--|--|--|--|--|--|--|--|--|--|--|

Hanbay Electronics:

| | | | | | | | |
|---|--|--|--|--|--|--|--|
| A | | | | | | | |
|---|--|--|--|--|--|--|--|

Hanbay Firmware:

| | | | | | | | | | | | | | | |
|---|--|--|--|--|--|--|--|--|--|--|--|--|--|--|
| A | | | | | | | | | | | | | | |
|---|--|--|--|--|--|--|--|--|--|--|--|--|--|--|

Serial number(s):

Valve Manufacturer:

Valve stroke length:

Valve Type:

Needle Valve

Other (specify)

Actuator TPI:

The Dipswitch settings we applied to your actuator are: (1="On", 0="Off")

| | | | | | | | | | | | |
|------|------|------|------|------|------|------|------|------|-------|-------|-------|
| Dip1 | Dip2 | Dip3 | Dip4 | Dip5 | Dip6 | Dip7 | Dip8 | Dip9 | Dip10 | Dip11 | Dip12 |
| | | | | | | | | | | | |

Notes & recommendations:

| FIRMWARE SETTINGS | | |
|-----------------------------|-----|--|
| LCL | | |
| FULL_RES | 0 | |
| LOW_TORQUE | 0 | |
| MULTI_TURN | 1 | |
| MULTI_TURN_EX_GEARSTAGE | 0 | |
| DEG_90 | 0 | |
| DEG_97 | 0 | |
| DEG_90_EX_GEARSTAGE | 0 | |
| DEG_97_EX_GEARSTAGE | 0 | |
| MIN_MOVE | 2 | |
| MIN_CHANGE_MOVE | 8 | |
| P_GAIN | 9 | |
| D_GAIN | 25 | |
| DECEL_REGION | 150 | |
| MAX_FULL_SPEED | 30 | |
| MAX_STALL_PERIOD | 6 | |
| TH_TO_DECEREAASE_RESOLUTION | 24 | |

| | | | | | | | | | | | | | | | | | |
|--|--|--|--|--|--|--|--|--|--|--|--|--|--|--|--|-------------------------|---------------------|
| L | | | | | | | | | | | | | | | | | MODEL NUMBER |
| ↓ Valve Manufacturers Valve Part Number/CU Number | | | | | | | | | | | | | | | | | |
| 0 No Valve or Mounting Kits | | | | | | | | | | | | | | | | | |
| 1 Mounting Kits Only | | | | | | | | | | | | | | | | | |
| 3 Valve with Mounting Kits, Mounted Assembly | | | | | | | | | | | | | | | | | |
| 4 Swagelok Bracket, Mounting Kits | | | | | | | | | | | | | | | | | |
| 5 Swagelok Bracket, Valve with Mounting Kits, Mounted Assembly | | | | | | | | | | | | | | | | | |
| 6 Drive lever only | | | | | | | | | | | | | | | | | |
| 7 External Stop | | | | | | | | | | | | | | | | | |
| AB Analog Signal Board Base Model | | | | | | | | | | | | | | | | DF Continuous TTL Input | |
| AI Analog Signal Board Isolated Model | | | | | | | | | | | | | | | | Analog Feedback | |
| AF Analog Signal Board Isolated with Feedback | | | | | | | | | | | | | | | | EF Continuous 24V TTL | |
| DC Continuous TTL Input Board | | | | | | | | | | | | | | | | Input Analog Feedback | |
| DT TTL Input Board | | | | | | | | | | | | | | | | | |
| SB Serial-Analog Signal Board Base Model | | | | | | | | | | | | | | | | ET 24V TTL Input Board | |
| SI Serial-Analog Signal Board Isolated Model | | | | | | | | | | | | | | | | | |
| 0 Nothing Special | | | | | | | | | | | | | | | | | |
| H Heater | | | | | | | | | | | | | | | | | |
| 0 Nothing Special | | | | | | | | | | | | | | | | | |
| 5 TURCK 5 Position Connector w. 20' Cable and Plug | | | | | | | | | | | | | | | | | |
| 6 TURCK 6 Position Connector w. 20' Cable and Plug | | | | | | | | | | | | | | | | | |
| 7 TURCK 5 Position Connector only | | | | | | | | | | | | | | | | | |
| 8 TURCK 6 Position Connector only | | | | | | | | | | | | | | | | | |
| 0 Nothing Special | | | | | | | | | | | | | | | | | |
| B Explosion proof B | | | | | | | | | | | | | | | | | |
| C Explosion proof C | | | | | | | | | | | | | | | | | |
| X Custom [see CU Number] | | | | | | | | | | | | | | | | | |
| L Linear | | | | | | | | | | | | | | | | | |
| M Manual Override | | | | | | | | | | | | | | | | | |
| F Fail-safe | | | | | | | | | | | | | | | | | |
| P Position Indication | | | | | | | | | | | | | | | | | |
| S Stainless Housing SS316 | | | | | | | | | | | | | | | | | |
| L Low J - Low Power Motor | | | | | | | | | | | | | | | | | |
| M Med K - Low Power Motor | | | | | | | | | | | | | | | | | |
| H High D - Low Linear 6 L with hanbay stage | | | | | | | | | | | | | | | | | |
| U Ultra High E - Med Linear 7 M with hanbay stage | | | | | | | | | | | | | | | | | |
| D Discrete | | | | | | | | | | | | | | | | | |
| C Continuous | | | | | | | | | | | | | | | | | |
| L - BLDC Linear Actuator | | | | | | | | | | | | | | | | | |

